

PP Drainage Systems

BlackMax® Pipe Dimensions

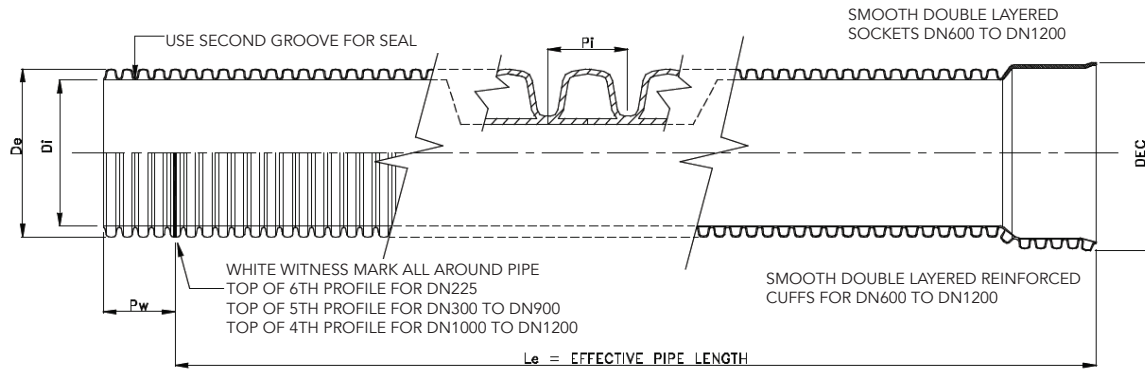

Technical Data

DN	Mean Pipe OD De (mm)	Mean Pipe ID Di (mm)	Socket OD DEC (REF) (mm)	Mean Witness Mark length Pw (mm)	Profile Pitch P _i (REF) (mm)	Approx Pipe Barrel Mass (kg/m)	Effective Lengths Le min (mm)
225	259	225	305	135	25	4	3000, 6000
300	344	300	403	147	33	6	3000, 6000
375	428	373	502	176	40	9	3000, 6000
450	514	447	603	222	50	13	3000, 6000
525	600	522	704	254	57	15	3000, 6000
600	682	596	750	296	66	21	2751, 5910
750	843	736	896	319	80	29	6000
900	1010	877	1072	398	100	39	6000
1000	1103	987	1187	TBA	TBA	TBA	TBA
1200	1342	1170	1432	476	133	73	TBA

Note:

- Standard nominal lengths in all diameters are 3m and 6m
- DN225 to DN525 are supplied with a ribbed socket
- DN600 to DN1200 are supplied with a double layered reinforced cuff

Need help? | Merchants 1300 0 47539 | Civil 13 10 86
www.iplex.com.au